



**CF350WH**

Dimensions (mm)	External	Internal
Height	840	
Width	1030	
Depth	755	
Capacity (ltr)		
Gross		350
Net		269



**CF450WH**

Dimensions (mm)	External	Internal
Height	840	
Width	1270	
Depth	755	
Capacity (ltr)		
Gross		450
Net		354



**CF550WH**

Dimensions (mm)	External	Internal
Height	840	
Width	1530	
Depth	755	
Capacity (ltr)		
Gross		550
Net		439



**CF650WH**

Dimensions (mm)	External	Internal
Height	840	
Width	1810	
Depth	755	
Capacity (ltr)		
Gross		650
Net		537

## Features

White laminated exterior including lid; stippled aluminium interior

Roll bond maintenance free condenser

Lock fitted as standard

Rollers fitted as standard

Replaceable door gasket

## Additional Extras

B9-BASKET - Basket for CF450/550/650

B9-GASKET450 - Gasket for CF450

B9-GASKET550 - Gasket for CF550

B9-GASKET650 - Gasket for CF650



## Technical Specification

	CF350WH	CF450WH	CF550WH	CF650WH
Temperature Range	-18°C ~ -22°C	-18°C ~ -22°C	-18°C ~ -22°C	-18°C ~ -22°C
Climate Class	4	4	4	4
Power Supply	13amp	13amp	13amp	13amp
Cooling	Static	Static	Static	Static
Defrost	Manual	Manual	Manual	Manual
Noise Level	48db	48db	48db	48db
Refrigerant	R600a	R600a	R600a	R600a
Energy Efficiency Class	F	F	F	F
Energy Consumption (kw/24hrs)	0.71	0.81	0.92	0.97
Power Usage (w)	64	138	161	161
Weight (kg)	57.5	65.5	75	83.5

### CF350WH

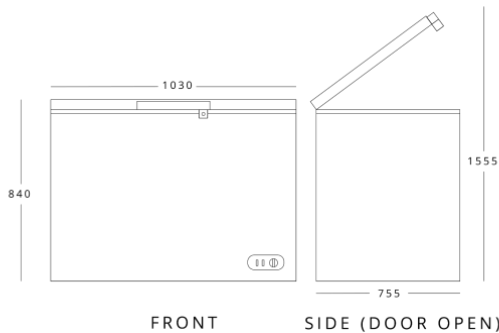

### CF450WH

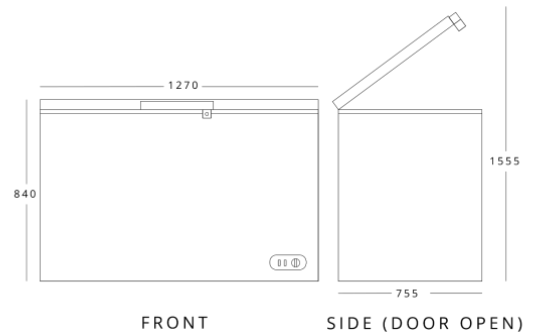

### CF550WH

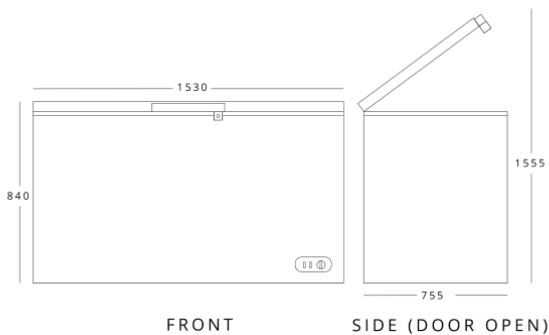

### CF650WH

