

# BSPIH

## Exploded parts diagram

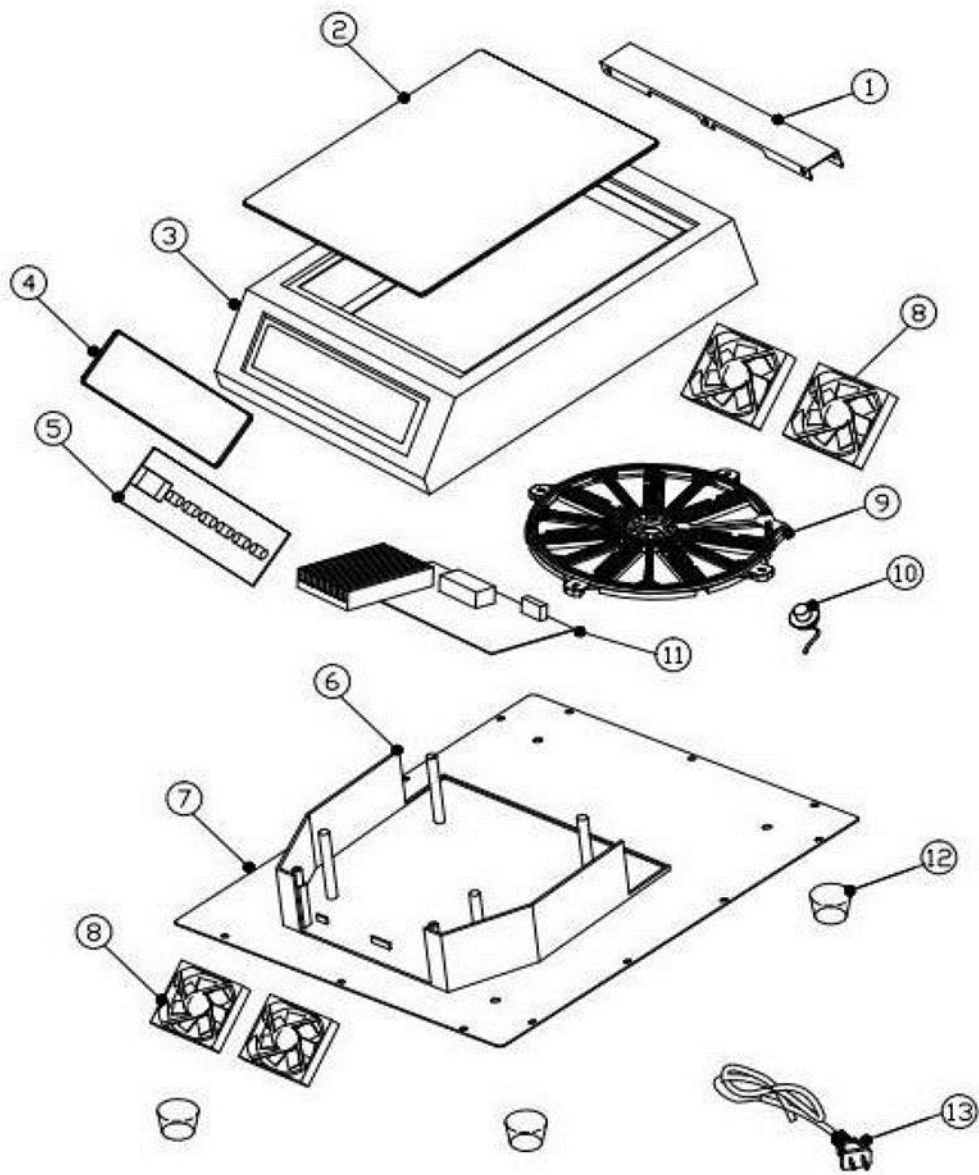





Part Number	Number	Description	Qty
***	1	Panel	1
***	2	Glass Plate	1
***	3	S/S Body	1
***	4	Control Plate	1
***	5	Control PCB	1
***	6	Inner Plastic Housing	1
***	7	Bottom Plate	1
***	8	Fan	2
***	9	Heating Coil	1
***	10	Sensor	1
B3-50012111	11	Mainboard	1
***	12	Feet	4
***	13	Power Co***rd	1

\*\*\* Please contact Spares for assistance \*\*\*