

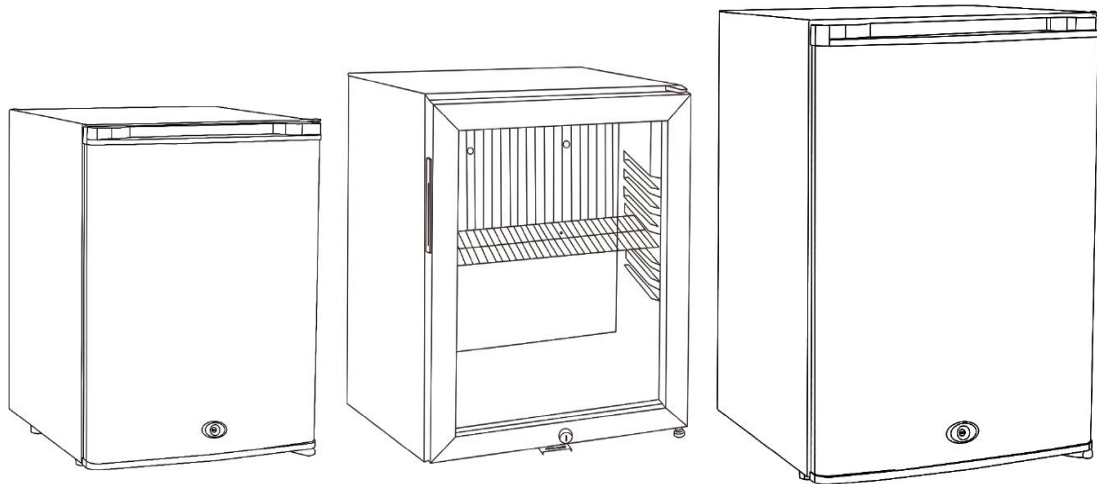

Minibar



ABSORPTION COOLER

Dear Customer,

Congratulations on your purchase of this product. This product has been produced using reliable and modern electrical components.

Please take a few minutes before starting operation of the appliance and read the following operating instructions.



Table of Contents

Important safety instructions.....	2
Intended use.....	3
Parts.....	4
Before first use	5
Installation instructions.....	5
Operation	6
Changing the door hinge	6
Cleaning and maintenance.....	10
Troubleshooting	10
Environmental protection	10
Technical data.....	11
Warranty.....	11

Important safety instructions



Read this instruction manual carefully before using the appliance. It contains important information for your safety as well as operating and maintenance advice.

1. Observe all safety instructions to avoid damage through improper use! Follow all warnings on the appliance.
 2. Keep this instruction manual for future use. Should this appliance be passed on to a third party, then this instruction manual must be included.
 3. No liability will be accepted for damage resulting from improper use or non-compliance with these instructions.
 4. Only use this appliance for its intended use. The appliance is intended for commercial use. This appliance is intended for indoor use only.
 5. Before connecting the appliance to the power supply, check that the power supply voltage and current rating corresponds with the power supply details shown on the appliance rating label.
 6. Never use a damaged appliance! Disconnect the appliance from the wall outlet and contact your supplier if it is damaged.
-
- DANGER OF ELECTRIC SHOCK!** Do not attempt to repair the appliance yourself. In case of malfunction, repairs are to be conducted by qualified personnel only.
7. To avoid damaging the cord, do not squeeze, bend or chafe it on sharp edges. Keep it away from hot surfaces and open flames as well.
 8. Lay out the cord in such a way that no unintentional pulling or tripping over it is possible.
 9. Do not use an extension cord.
 10. Do not place heavy objects on top of the appliance. Do not place objects with open flames, e.g. candles, on top of or beside the appliance. Do not place objects filled with water, e.g. vases, on or near the appliance.
 11. This appliance is not intended for use by persons (including children) with reduced physical, sensory, or mental capabilities, or by those who lack experience and knowledge, unless they have been given supervision and instruction concerning the use of the appliance by a person responsible for their safety.
 12. Children should be supervised to ensure that they do not play with the appliance.
 13. For additional protection, we recommend the use of a residual current device (RCD) with a tripping current not exceeding 30mA in the electrical circuit supplying power to your appliance.
 14. Keep the appliance away from any hot surfaces and open flames. Always operate the appliance on a level, stable, clean and dry surface. Protect the appliance against heat (over 35°C) and cold (under 15°C), dust, direct sunlight, moisture, dripping and splashing water.
 15. This appliance is classified as protection class I and must be connected to a protective earth (ground).
 16. Regularly check the power plug and power cord for damage. If the supply cord is damaged, it must be replaced by the manufacturer, its service agent or similarly qualified persons in order to avoid a hazard.
 17. Do not pull the power plug out of the wall outlet by the power cord and do not wrap the power cord around the appliance.

Important safety instructions

18. Connect the power plug to an easily reachable wall outlet so that in case of an emergency the appliance can be unplugged immediately. Pull the power plug out of the wall outlet to completely switch off the appliance. Use the power plug as the disconnection device.
19. Disconnect the power plug from the wall outlet when not in use and before cleaning.
20. The appliance is powered when connected to the power supply.
21. Maximum loading of shelf in storage compartment is 8kg.
22. Maximum loading of door balcony is 5kg.
23. Oil leaks can damage the door's rubber seals. Make sure that products containing oil are well wrapped and do not leak.
24. In the event of fire, first pull the power plug out of the power outlet or disconnect the appliance from the power supply otherwise before taking appropriate measures to fight the fire.

WARNING! The refrigeration system is under high pressure. Do not tamper with it. Contact qualified service personal before disposal.

- Keep clear of obstruction all ventilation openings in the appliance enclosure or in the structure for building-in.
- Do not use mechanical devices or other means to accelerate the defrosting process, other than those recommended by the manufacturer. Do not use any heat sources, such as candles or heaters, to speed up defrosting.
- Do not damage the refrigerant circuit.
- Do not use electrical appliances inside the food storage compartments of the appliance, unless they are of the type recommended by the manufacturer.



DANGER OF FIRE AND EXPLOSION!

- Do not use the appliance near explosive or flammable vapours.
- Do not store any explosive or flammable substances, like benzine, liquid gas or glue, in the appliance.



- If gas flows out of the appliance, do not pull the power plug from the outlet as this can cause sparks and fire.



- Do not store explosive substances such as aerosol cans with a flammable propellant in this appliance.

● **CAUTION: RISK OF FIRE!**



WARNING! To avoid a hazard due to instability of the appliance, it must be installed according to the instructions.

Intended use

This absorption refrigerator is intended for keeping snacks and drinks cold and fresh. Do not store food as the interior temperature may not be cool enough to prevent spoilage. This absorption refrigerator is intended for commercial use or similar use.

Parts

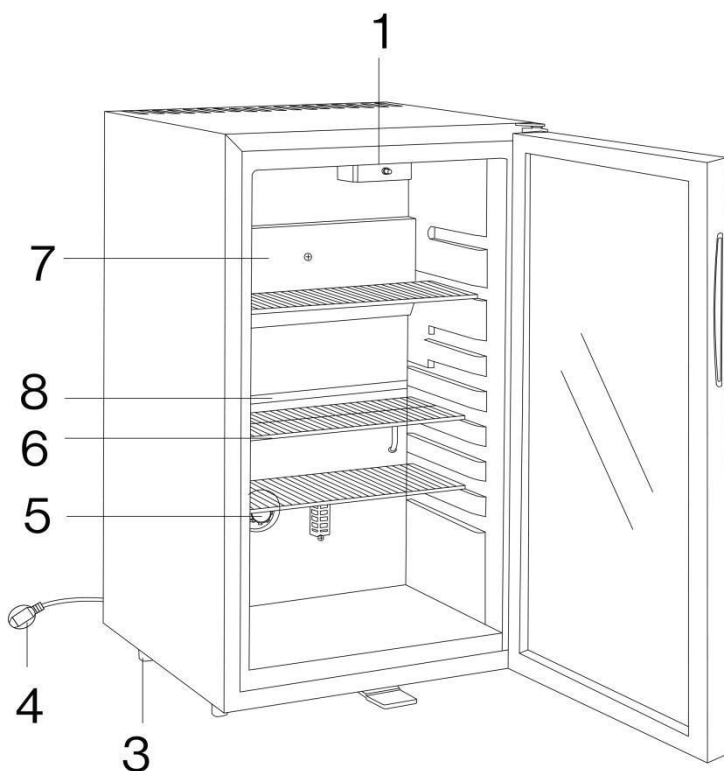
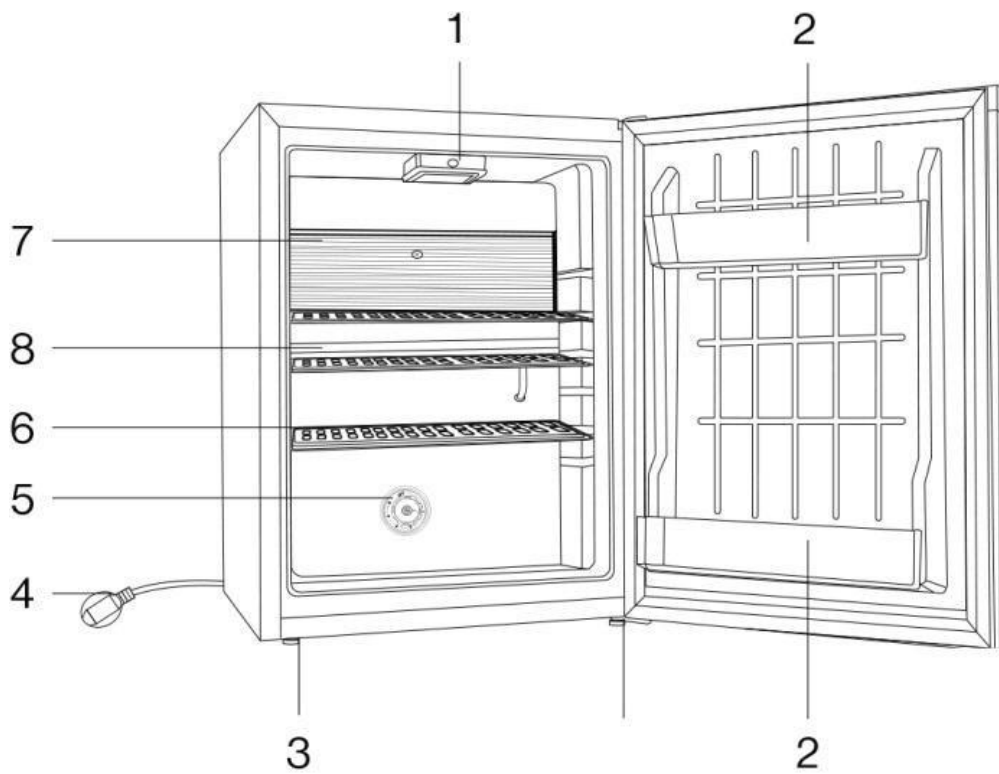

- 1. Lamp
- 2. Door shelf
- 3. feet
- 4. Power cord with power plug
- 5. Temperature knob 1-3
- 6. Shelf *MB30(qty1) MB40(qty2)*
- 7. Cold sink (Evaporator)
- 8. Water tray

NOTE! Left hand hinge kit supplied.

Before first use

- Remove all packaging materials.
- Check for completeness and damage that may have occurred while transporting the product. In case of damage or incomplete delivery, please contact your dealer (Guarantee).
- Clean the appliance (Cleaning and maintenance).
- Make sure all parts of the appliance are completely dry.
- Place the appliance on a horizontal, stable, and heat-resistant surface. Make sure the refrigerator is in the horizontal position; ensure cabinet is level.
- Ensure that there is sufficient ventilation. Keep a minimum distance of 10cm between the product and other objects or walls.



Note: After moving the refrigerator, allow it to sit in an upright position for 20 to 30 minutes prior to plugging it into a power outlet.

Installation instructions

Ideas for saving energy

- Locate the product in the coolest part of the room, out of direct sunlight, and away from sources of heat. If this is not possible, a section of cabinetry or an added layer of insulation will help the refrigerator operate more efficiently.
- Level the refrigerator so that the door closes tightly.
- From time to time, adjust the temperature inside the refrigerator, since it changes along with:
 - the room temperature
 - the frequency at which the refrigerator door is opened and how long it stays open
 - the items inside
- Place the stored product 2cm away from the internal walls.
- Do not cover the product's ventilation openings.



Installation inside a closet

When placing the refrigerator inside a closet or on a shelf, keep a fixed distance between the refrigerator and all the walls. The closet should have adequate ventilation provided. For details, refer to the illustrations below:

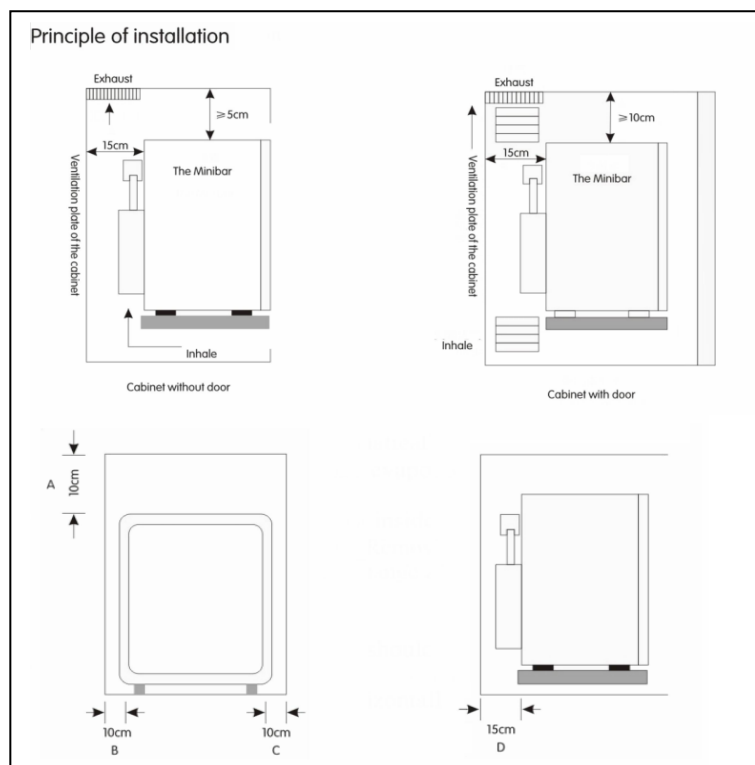

Operation

Connect the power plug to a suitable wall outlet.

Turn the temperature knob (5) to adjust the temperature. Setting 1 is the highest temperature and setting 5 is the lowest temperature.

Temperature knob: 1 - 3

1 - highest temperature setting (10 - 12°C)

3 - lowest temperature setting (3 - 5°C)

Changing the door hinge

NOTE! Ensure the unit is disconnected from the electrical supply and is totally empty prior to reversing the door. Ensure you have located the Left-hand door hinge kit (supplied).

- Remove the upper right screws and screw covers.



- Gently pull away the door and remove the upper hinge bracket from cabinet and the door.



Changing the door hinge

- Remove the blanking plate from the upper left-hand hinge position and reposition and secure to the right-hand upper hinge position using the original screws and screw covers.



- Remove the lower door hinge and pivot, carefully lay the cabinet on its back and remove the lower hinge plate. Secure the left-hand lower hinge plate (supplied) to the left-hand side of the base using the original securing screws. Ensure the lower door pivot is positioned correctly on the left-hand hinge plate.



Changing the door hinge

- Position the door onto the lower door hinge pivot, and position the top left-hand hinge bracket(supplied) on the top of the door and insert into the cabinet, verify the correct door alignment and tighten the securing screws and screw covers.



- If door alignment is incorrect, loosen door hinge brackets, align door and retighten the bracket securing screws. If the seal does not pull to correctly, warm the seal to soften the rubber and close the door ensuring the door seal has no gaps or deformation.

Cleaning and maintenance

Cleaning



Before cleaning and maintaining the product, disconnect the power plug from the wall outlet.

- Remove all items from the refrigerator.
- Wipe the inside and outside surfaces using a damp cloth.
Tip: Add some vinegar into the water to prevent the refrigerator from growing mold.
- After cleaning, wipe all parts thoroughly and allow them to dry.
- Do not use abrasive sponges or cleaning agents, steel wool, or metallic utensils to clean the interior or exterior of the appliance.



Important! When the refrigerator is not in use, ensure it is completely dry inside, so as to avoid mold growth. If possible, leave the refrigerator door open.

Light bulb replacement

- If the light bulb is damaged, do not try to fix it by yourself. It must be replaced by the manufacturer, its service agent or similarly qualified persons in order to avoid a hazard.

Troubleshooting

Fault	Remedy
The appliance does not cool.	Verify if the supply voltage and power cable is correct
	Verify if the power cable is connected correctly.
	Verify their s sufficient ventilation around the cabinet and vents are not blocked.
	Verify if the thermostat switch is set correctly.
	Disconnect from power supply, empty contents, dry out any moisture, carefully invert cabinet for 20 minutes, re-position and level the unit, leave to stand for 20 minutes before connecting to the power supply.
The appliance does not reach the cooling temperature.	Verify if the thermostat switch is set correctly.
	Make sure that the appliance is placed on a horizontal level surface.
	Put exclusively cold products into the appliance.
	Do not overfill the appliance.
	Make sure that the door of the appliance is only open when required.
	Verify if the door of the appliance closes correctly and seals completely.

Environmental protection

Proper disposal of refrigerators

- Before you dispose of an old refrigerator:
 - Remove the doors.
 - Leave the shelves in place so children cannot easily climb inside.
 - Have the refrigerant circuit removed by a qualified service technician.
- Do not damage the refrigerant circuit during storage and transportation of old appliances! Make sure that the evaporator pipes, refrigerant circuit, and surface coverings are not damaged. Avoid contact with the eyes as the refrigerant can cause serious eye injury.
- Do not store old appliance near sources of heat and ignition. The refrigerant of this appliance is highly flammable.
- Disable discarded appliances by unplugging the plug and cutting the power cord.



Discarded electric appliances are recyclable and should not be discarded in the domestic waste! Please actively support us in conserving resources and protecting the environment by returning this appliance to the collection centres (if available).

**Pentland Wholesale Ltd, Blizzard house, Unit17 Walker Park Industrial Estate,
Walker Road, Blackburn, Lancs, BB1 2QE. Tel: 01254 614444,**

www.pentlandwholesale.co.uk

Technical data

Model	30 Lt. Minibar	40 Lt. Minibar	
Climate Class	N	N	N
Refrigerant Gas	NH3	NH3	NH3
Refrigerant Charge	Please refer to the information indicated on the product. You will find the information on the rating label on the back of the unit as well as inside the cooling compartment. The circuit diagram is displayed on the back of the unit as well as inside the cooling compartment		
Temperature Range (°C)			
Input Power			
Rated Frequency			
Rated Voltage			
Internal volume			
Net Weight			
Gross Weight			
Foaming Agent			

Warranty

A statutory warranty applies for this product.

Damages caused by wrong treatment or operation, by false placement or storage, improper connection or installation, as well as force or other external influences are not covered by this warranty. We recommend careful reading of the operating instructions as it contains important information.

Note:

1. In case this product does not function correctly, please firstly check if there are other reasons, e.g. for electrical appliances interruption of the power supply, or generally incorrect handling are the cause.
2. Please note that, where possible, the following documents or rather information should be provided together with your faulty product:
 - Purchase receipt
 - Model description/ Type/ Brand
 - Describe the fault and problem as detailed as possible

In the case of a claim for guarantee or defects, please contact the seller.



